



Model 450 Transporters



Save time and money by eliminating conveyor-related downtime, maintenance and repair.



P.O. Box 209, Port Royal, PA 17082
Tel: 717.527.2094 Fax: 717.527.2180
Email: info@vibroindustries.com
Web: www.vibroindustries.com

The Vibro Model 450 Air-Operated Transporter can move up to 125 lbs. of material effortlessly (operating at 35 PSI - 0.4 CFM), including linear scrap removal from machine tools and for other conveying processes. The Model 450 has a total capacity of 170 lbs., plus 60 lbs of tray weight. Plus, multiple trays can be mounted on a single unit, replacing several conventional belt conveyors. The compact design of the Vibro Transporter allows installation in tight areas.

Specifications

| | Model 450 |
|-------------------------|------------------------------|
| Air Pressure Range | 35 - 80 |
| Air Consumption (CFM) | 60 psi - 1.9 35 psi - 0.4 |
| Feed Rate (feet/minute) | 15 - 40 |
| Sound Level (db-A) | 64 |
| Maximum Load | 125 lbs. |
| Max. Weight of Tray | 60 lbs. |
| Transporter Weight | 30 lbs. |

Vibro Features Include:

- Two Year Warranty
- 100% Air Operated (no mechanical springs)
- Low Air Consumption
- Variable Speed (12-40 ft./min.)
- Available from Stock
- 100% American Made

Optional Features Include:

- A Cover Guard for harsh environments
- Quick Clamps for fast tray removal
- Adjustable Bearing Support for trays
- A Motion Sensor that automatically shuts down machinery if the air supply is ever interrupted

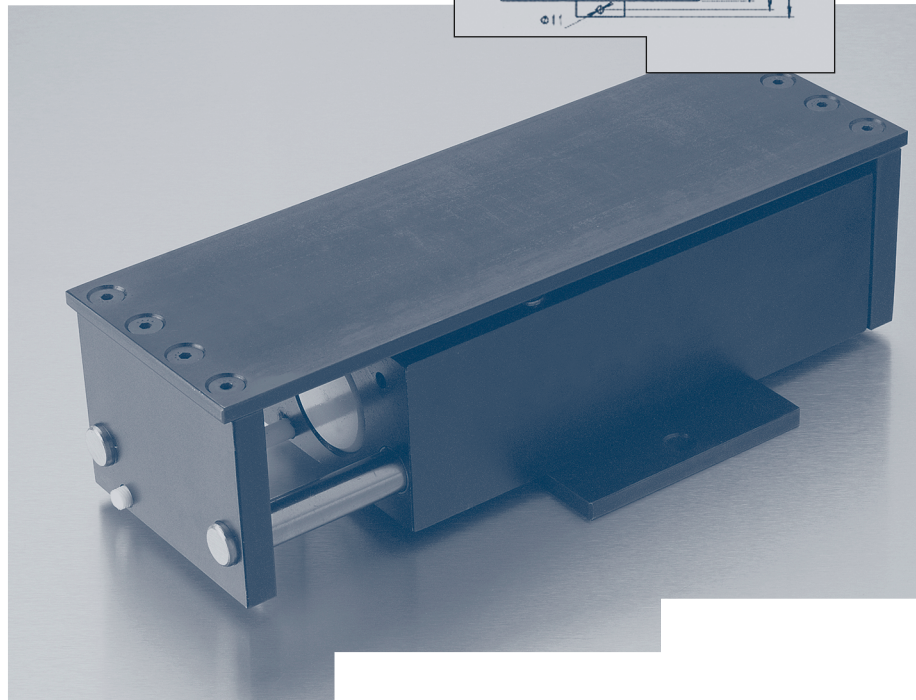
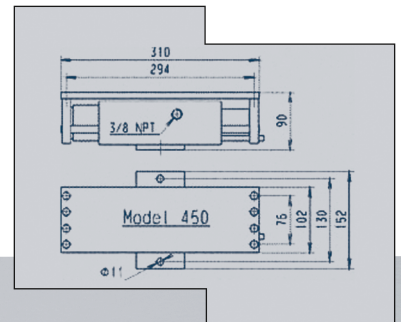

Global Distribution

